



ERG-E SERIES

SINGLE STAGE
PRESSURE REGULATOR WITH
SAFETY SHUT-OFF VALVE
MAX PRESSURE 1 BAR

ERG-E

Gas pressure regulators of the ERG-E series are used in the gas distribution lines to reduce the maximum input pressure of 1 bar at the desired output pressure between 16 and 150 mbar. The output pressure range can be set by choosing springs of a different type. The regulator with safety shut-off valve stops the flow of gas if the pressure increases or decreases compared to the set values so as to ensure the safety of operation

Technical Features

- Usage: gas networks and networks in industrial areas
- Fluid types: natural gas, LPG and non corrosive gases
- Pressure class: PN1
- Connections: 1/2", 3/4", 1", 1 1/4", 1 1/2", 2" Threaded (Female). Flanged version on request
- Upstream pressure range: 50 mbar to 1 bar
- Downstream calibration pressure: 16 mbar up to 150 mbar
- Flow rate: 20-120 Stm³ / h
- Filter: 50 micron (10-20 microns on request)
- Construction materials: aluminum body and cover, nitrile rubber NBR membrane, springs in AISI 302
- Precision class: AC 10 (± 10%) (On Request AC5, AC15, AC20)
- Overpressure closure: SG30 (+ 30%) (upon request SG10, SG20))
- Ambient temperature: - 20 ° C up to 60 ° C (on request - 40 ° C)
- Maximum pressure safety shut-off valve (OPSO): 30 mbar up to 200 mbar
- Minimum pressure safety shut-off valve (UPSO): 12 mbar up to 40mbar
- Regulators comply with EN88-2 and UNI 8827 1-2 standards



Packing data

MODEL	CONNECTIONS	WEIGHT	BOX DIMENSIONS (LxPxH cm)	PACKING (piece/pack)	PACK DIMENSIONS (LxPxH cm)	PACK WEIGHT (Kg)	TOTAL WEIGHT (Kg)
ERG-E 1015	1/2"	1,50 Kg	15,5x13x18	15	50x50x30	0,85	23,35
ERG-E 1020	3/4"	1,50 Kg	15,5x13x18	15	50x50x30	0,85	23,35
ERG-E 1025	1"	1,50 Kg	15,5x13x18	15	50x50x30	0,85	23,35
ERG-E 1032	1 1/4"	3,75 Kg	24x23x24	4	50x50x30	0,85	15,85
ERG-E 1040	1 1/2"	3,75 Kg	24x23x24	4	50x50x30	0,85	15,85
ERG-E 1050	2"	3,75 Kg	24x23x24	4	50x50x30	0,85	15,85

Dimensions

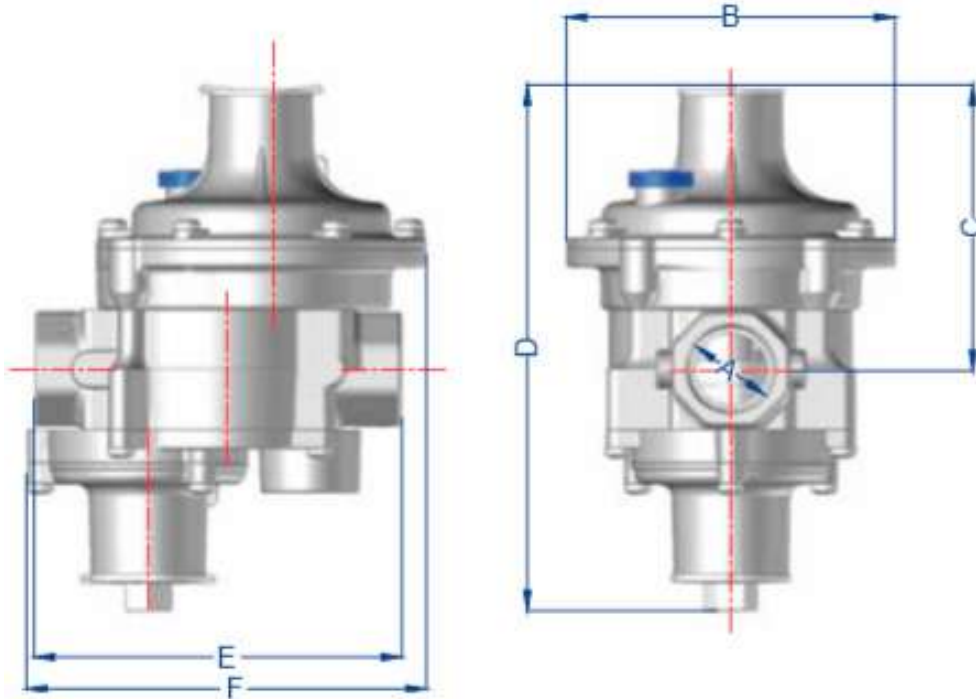

MODEL	A	B	C	D	E	F
ERG-E 1015	1/2"	122 mm	106 mm	198 mm	136 mm	146 mm
ERG-E 1020	3/4"	122 mm	106 mm	198 mm	136 mm	146 mm
ERG-E 1025	1"	122 mm	106 mm	198 mm	136 mm	146 mm

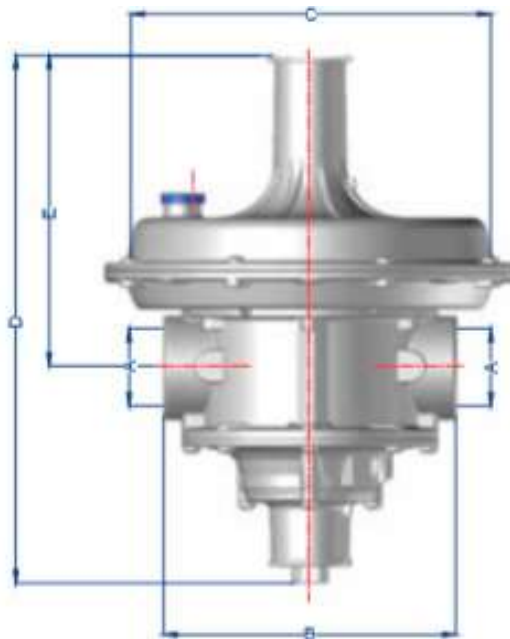

MODEL	A	B	C	D	E
ERG-E 1032	1 1/4"	160 mm	225 mm	237 mm	183 mm
ERG-E 1040	1 1/2"	160 mm	225 mm	237 mm	183 mm
ERG-E 1050	2"	162 mm	225 mm	259 mm	192 mm

Product range



Rotary piston gas meters



Turbine gas meters



Gas pressure regulators



Electronic volume correctors



Diaphragm gas meters



Smart meters

metrixitalia

Metrix Italia s.r.l.

Via Nona Strada 53 - 35129 Padova (Italy)

Tel: +39 049 5349377 - Fax: +39 049 8076008

www.metrixitalia.it - E-mail: info@metrixitalia.it